

THIS LIFT IS MANUFACTURED TO AS1735.16 FOR RESTRICTED USE

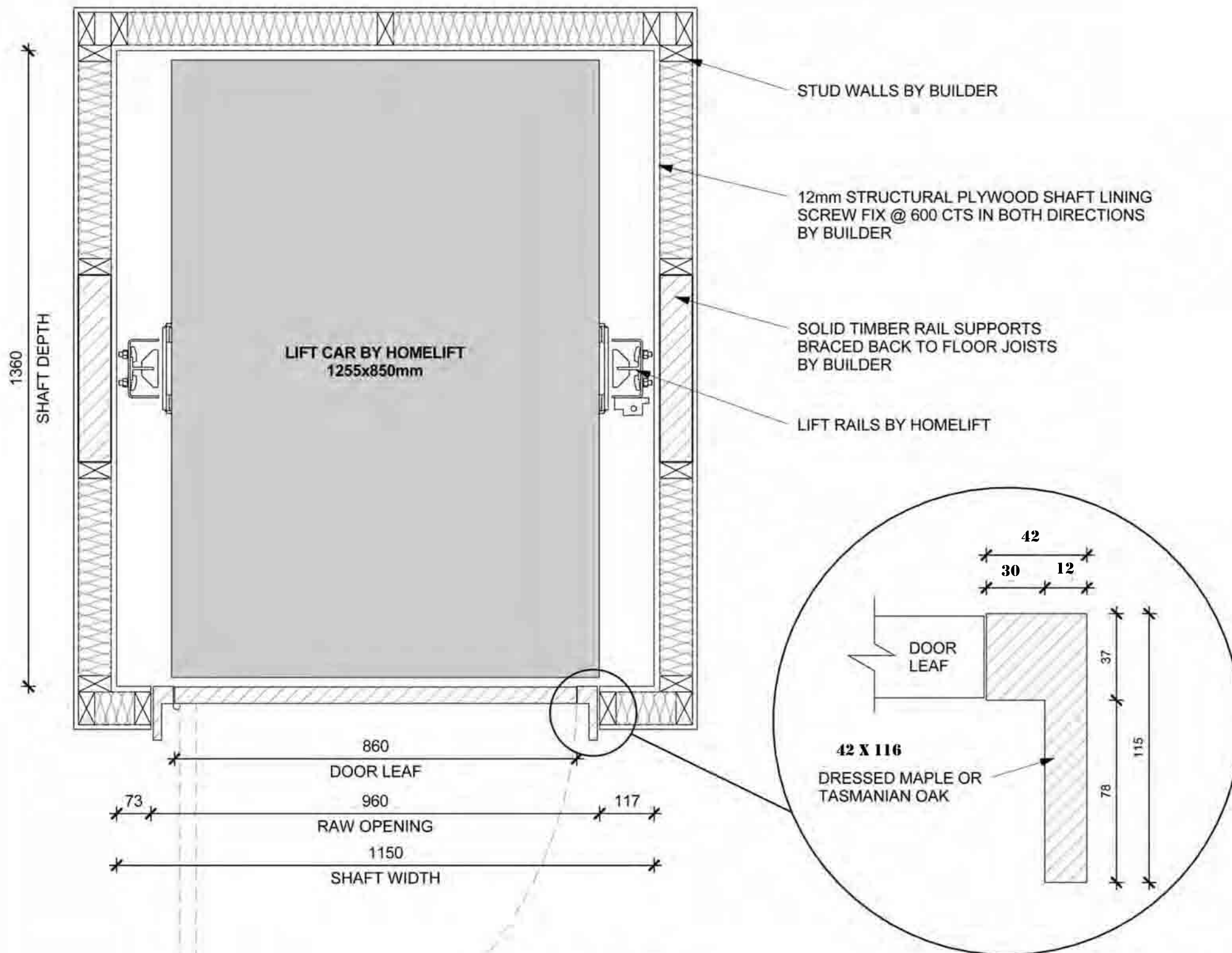

ATRIUM SPECIFICATIONS:

- DRIVE: ROPED DRUM - BRAKED GEAR MOTOR
- MAX TRAVEL 7000mm
- HEAD ROOM: MIN 2400mm AT TOP FLOOR
- PIT DEPTH: MIN **120 MM**
- SHAFT SIZE: 1150x1360mm
- LIFT CAR FLOOR AREA: 850x1255mm
- LOAD: 250 Kg
- SPEED: UP TO 0.25 m/s
- POWER: 15A SINGLE PHASE (DEDICATED CIRCUIT) THROUGH CAR CONFIGURATION OPTIONAL

BUILDERS TOLERANCES:

- SHAFT DIMENSIONS: -0mm / +10mm
- DIAGONALS: WITHIN 10mm
- DOOR FACES PLUMB: -3mm / +3mm
- DOOR OPENINGS INLINE
- PIT DEPTH: MIN **120 MM** (TO BE CONFIRMED BY BUILDER / CLIENT)

BUILDERS WORKS:

- SHAFT CONSTRUCTION
- INTERNAL **12MM PLYWOOD LINING**
- LANDING CALL STATION CHASING (IF REQUIRED)
- DOOR JAMBS
- SOLID CORE DOOR & HARDWARE (EXCLUDING LOCKS)
- EXTERIOR LIGHTING AT LANDING (75 LUX MINIMUM)
- POWER SUPPLY & PHONE LINE TO SHAFT AS INDICATED
- CLEAR, UNOBSTRUCTED DELIVERY ACCESS TO LIFT AREA.

ALL BUILDERS WORKS MUST BE COMPLETED PRIOR TO DELIVERY & COMMENCEMENT OF INSTALLATION

PLAN OF LIFT CAR scale: 1:10 @ A3

DOOR JAMB / FRAME PROFILE scale: 1:2 @ A3

Homelifts
by Cranetec

55-59 Market Street Smithfeild ,NSW 2164
Telephone 1800 703 470 Fax (02)9609 1833
Email John@cranetec.com.au
www.homelift.com.au

ATRIUM
LIFT SHAFT - PLAN

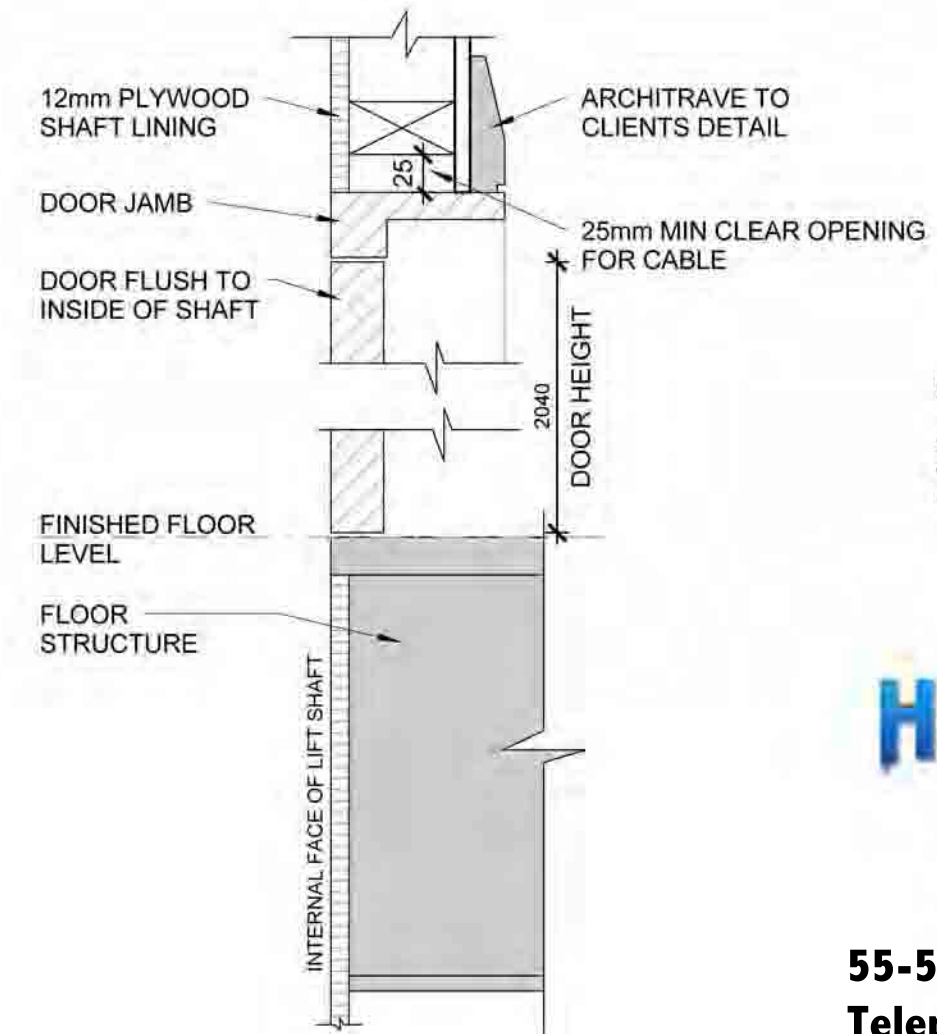
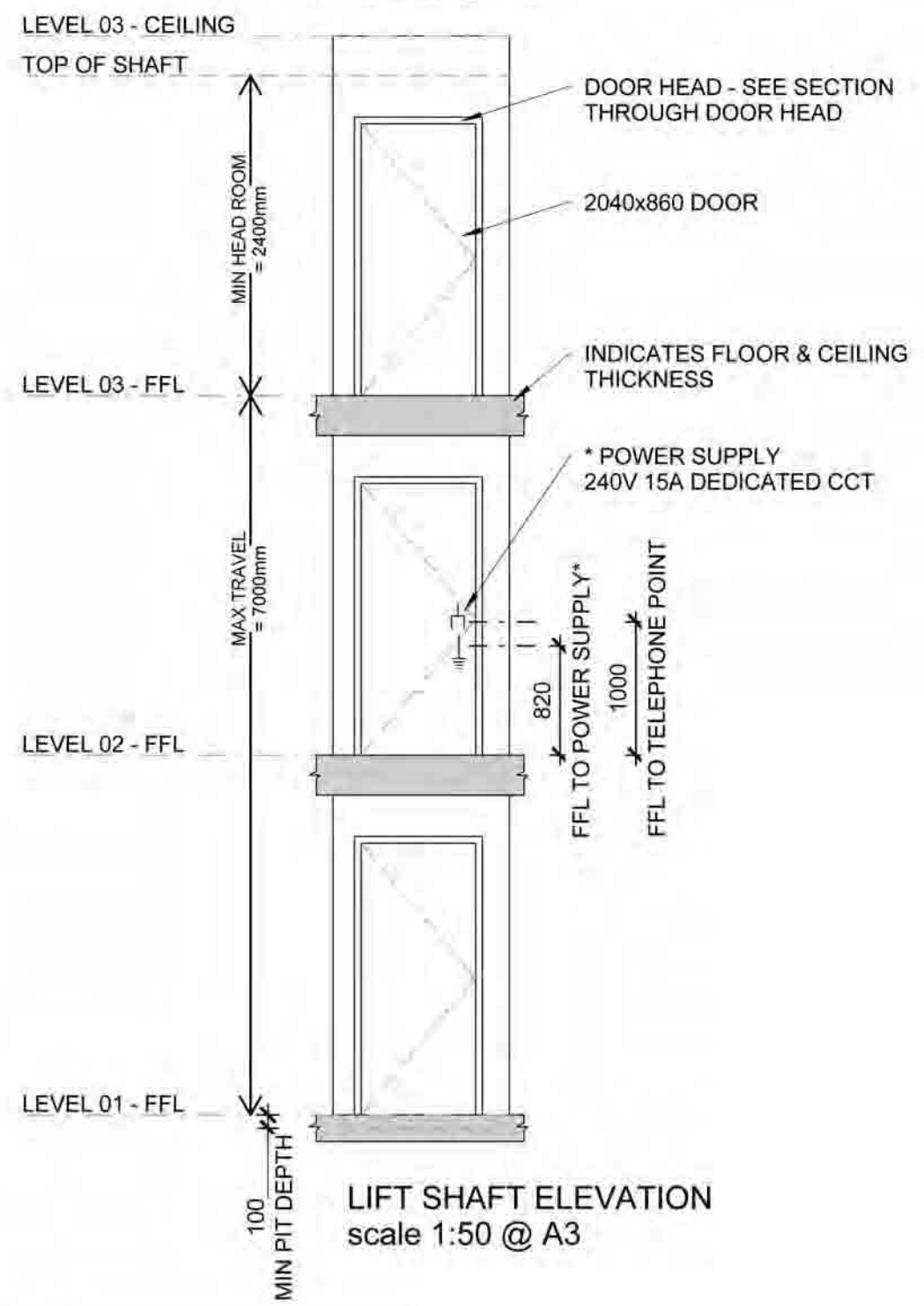
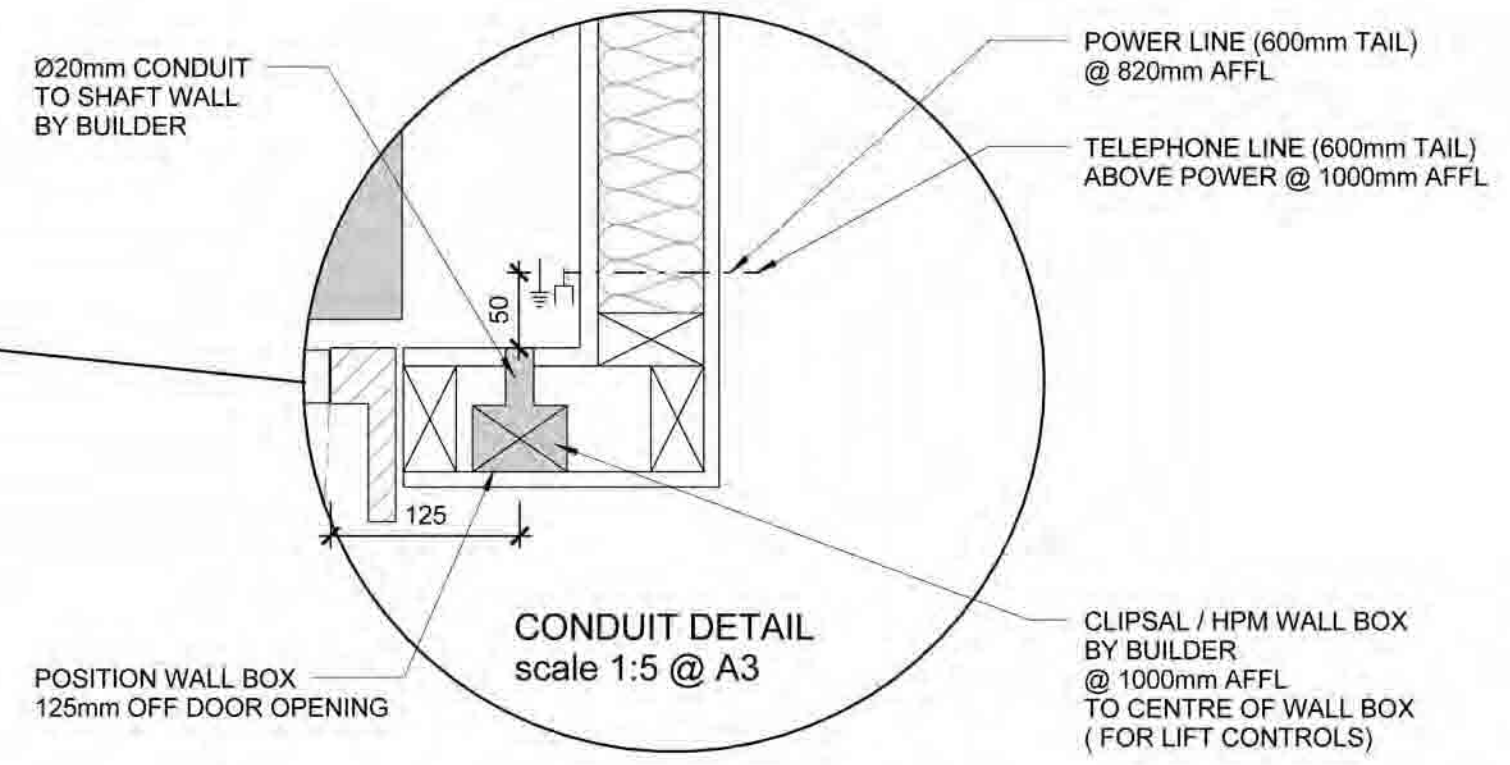
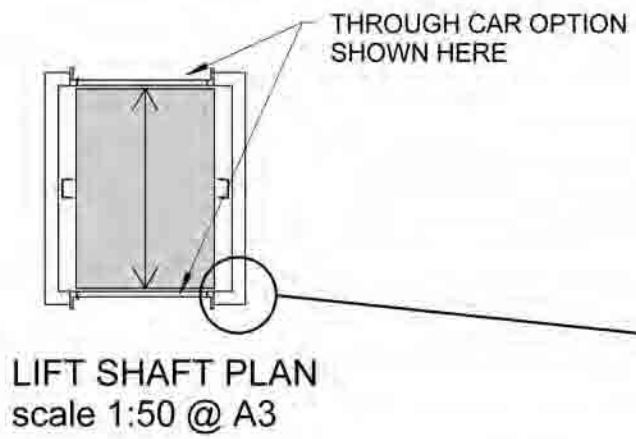

NOTES:

- STD WALL PLATE OR WALL BOX BY BUILDER.
- CONDUIT THROUGH WALL TO SHAFT BY BUILDER.
- POWER & PHONE LINES MUST BE LIVE PRIOR TO INSTALLATION COMMENCING.

**Homelifts
by Cranetec**

55-59 Market Street Smithfield ,N.S.W 2164
Telephone 1800 703 752 Fax (02) 9609 1833
Email John@cranetec.com.au
www.homelift.com.au

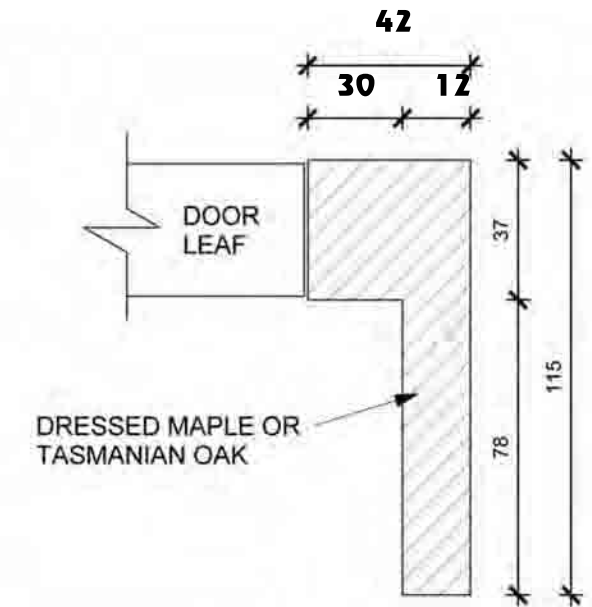
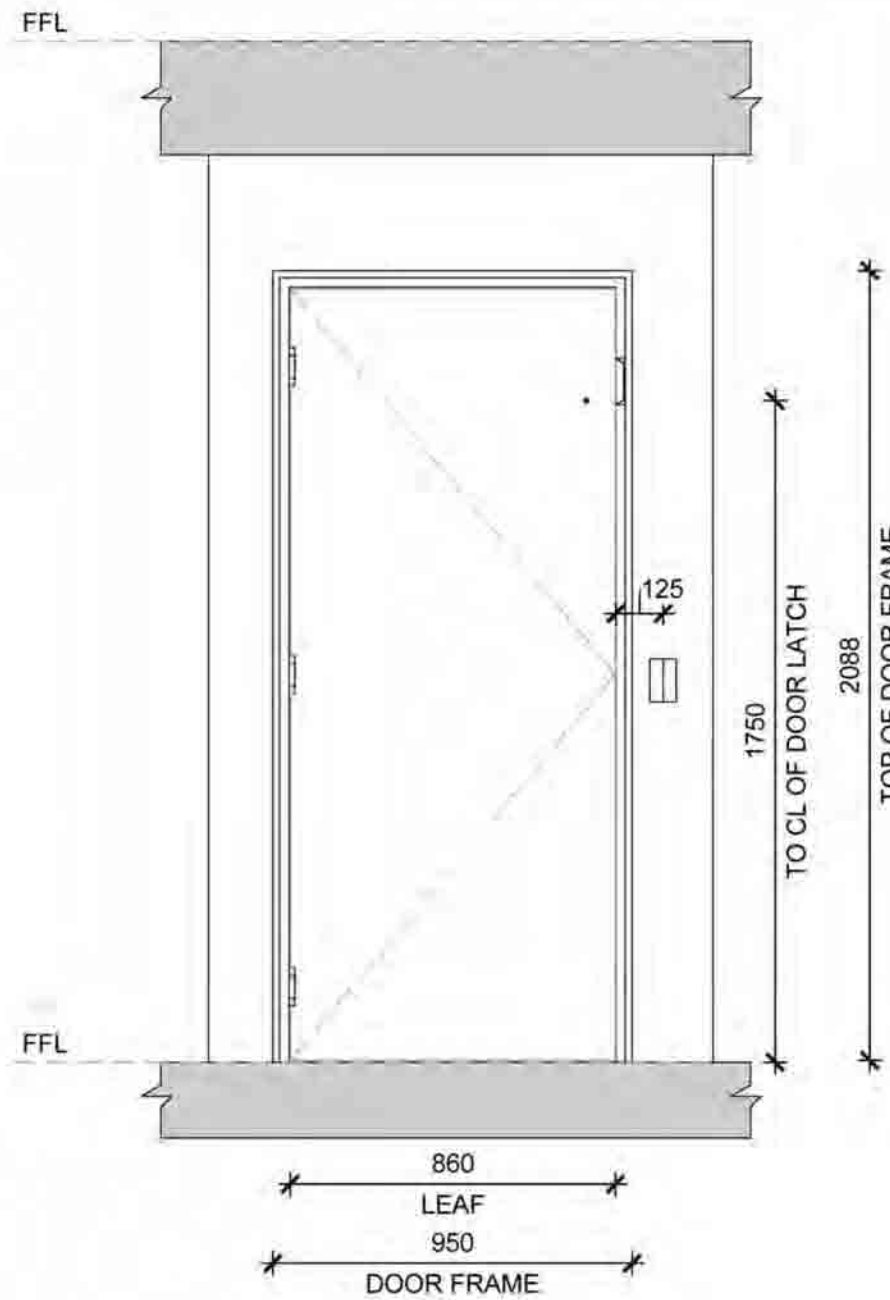
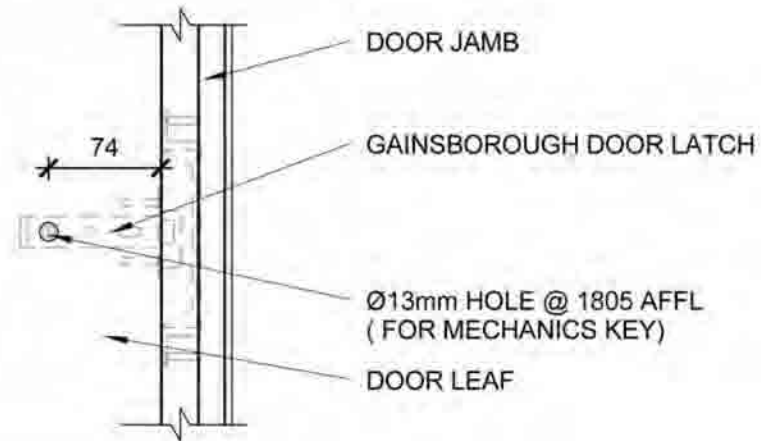
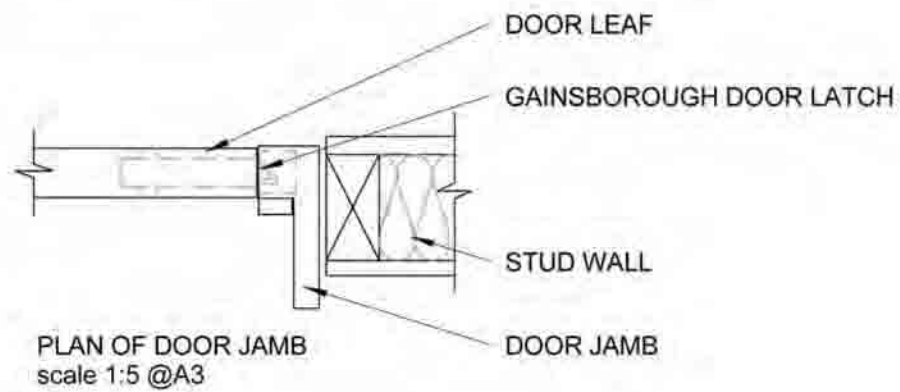
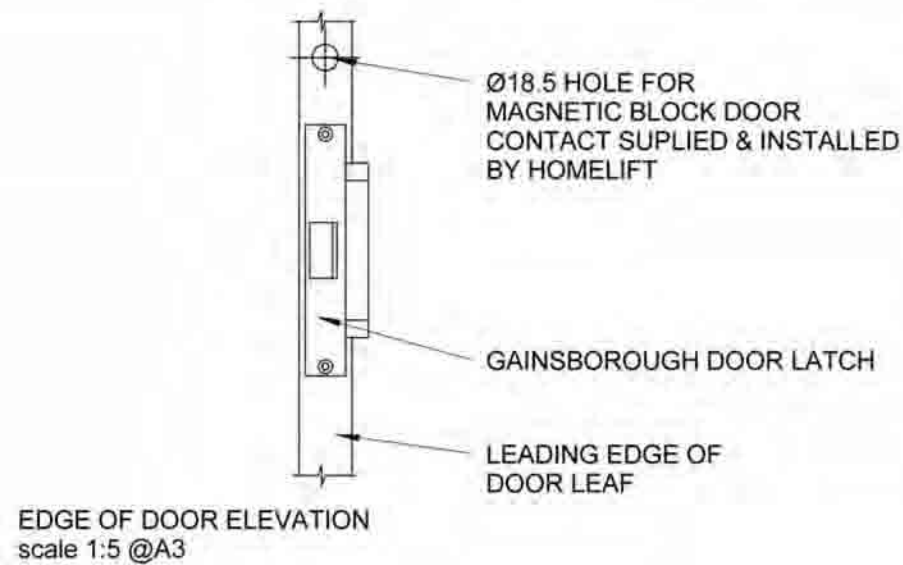

DOOR JAMB / FRAME PROFILE
scale: 1:2 @ A3

GENERAL NOTES:

- GAINSBOROUGH DUAL SPRUNG TUBULAR LATCH SUPPLIED BY HOMELIFT & INSTALLED BY BUILDER TO MANUFACTURERS INSTRUCTIONS.

DOOR NOTES:

- 2040x860x35mm DOOR LEAF WITH 3 x 100HD BUTT HINGES
- "D" HANDLE TO TO EXTERNAL DOOR FACE (LANDING)
- PUSH PLATES TO INTERNAL DOOR FACE (SHAFT)
- INTERNAL SHAFT VERTICLE FACE TO BE SMOOTH & FLUSH WITH INTERNAL FACE OF LANDING DOOR FRAMES +-3mm

Homelifts
by Cranetec

55-59 Market Street Smithfeild ,N.S.W 2164
Telephone 1800 703 752 Fax (02) 9609 1833
Email John@cranetec.com.au
www.homelift.com.au

ATRIUM

DOOR & FRAME DETAILS